

46 : Active On demand Coupling, AOC -2008

XC90, 2007

26/3/2013



PRINT

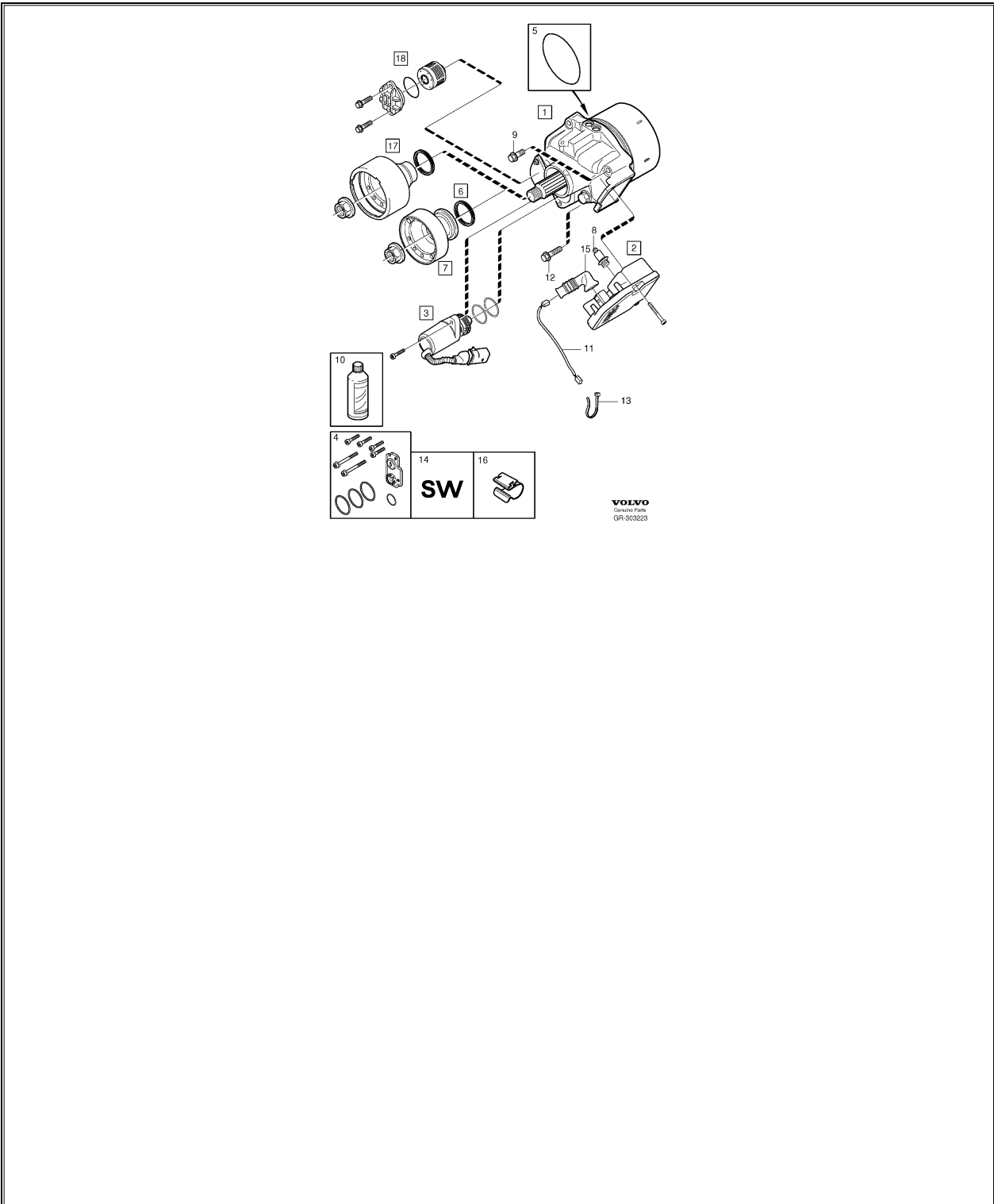

Fig.	Description	Qty.	PS	Part number
<input type="checkbox"/> 1	Clutch, exch REPL 1 PCS 36000140.	1.00	EU	8603666
<input type="checkbox"/>	Clutch, exch	1.00	EU	36000140

		REPL 1 PCS 36000568.			
<input type="checkbox"/>		Clutch, exch	1.00	EU	36000568
<input type="checkbox"/>	2	* Control unit, exch w/o coil, , (30783061), , (30759702)	1.00	EU	36001751
<input checked="" type="checkbox"/>		** Ecu	1.00	NS	
<input checked="" type="checkbox"/>		** Restricting valve	1.00	NS	
<input checked="" type="checkbox"/>		** Screw	2.00	NS	
<input checked="" type="checkbox"/>		** Gasket	1.00	NS	
<input checked="" type="checkbox"/>		** Spring washer	1.00	NS	
<input checked="" type="checkbox"/>		** O-ring	1.00	NS	
<input type="checkbox"/>	3	* Oil pump kit (8689664)	1.00		30783079
<input checked="" type="checkbox"/>		** Oil pump	1.00	NS	
<input checked="" type="checkbox"/>		** Screw	2.00	NS	
<input checked="" type="checkbox"/>		** O-ring	2.00	NS	
<input type="checkbox"/>	4	* Repair kit (8689668)	1.00		30783288
<input checked="" type="checkbox"/>		** Plate For control module (ECU).	1.00	NS	
<input checked="" type="checkbox"/>		** Gasket For control module (ECU).	1.00	NS	
<input checked="" type="checkbox"/>		** Screw M5x60, For control module (ECU).	2.00	NS	
<input checked="" type="checkbox"/>		** Screw M5x18, For oil pump kit.	2.00	NS	
<input checked="" type="checkbox"/>		** O-ring 32x2.5 mm, For oil pump kit.	1.00	NS	
<input checked="" type="checkbox"/>		** O-ring 29.6x2.4, For oil pump kit.	1.00	NS	
<input checked="" type="checkbox"/>		** O-ring 34.2x3 mm, For filter.	1.00	NS	
<input checked="" type="checkbox"/>		** Screw M5x18, For filter.	2.00	NS	
<input type="checkbox"/>	5	* O-ring This O-ring differs from the one installed from the factory. The factory installed O-ring is square, the spare part is round.	1.00		925263
<input type="checkbox"/>	6	* Sealing kit	1.00		8675238
<input checked="" type="checkbox"/>		** Sealing	1.00	NS	
<input type="checkbox"/>		** Flange lock nut M16x1.5x10	1.00		31259267
<input type="checkbox"/>	7	* Companion flange, kit CH 445554-495000	1.00		31256140
<input type="checkbox"/>		* Companion flange, kit CH 495001-	1.00		31259350
<input checked="" type="checkbox"/>		** Companion flange	1.00	NS	
<input checked="" type="checkbox"/>		** Dust cover	1.00	NS	
<input type="checkbox"/>		** Flange lock nut M16x1.5x10	1.00		31259267
<input type="checkbox"/>	8	* Pressure sensor CH -256826, , 40 BAR	1.00		30651694
<input type="checkbox"/>		* Pressure sensor CH 256827-, , 80 BAR	1.00		30759668
<input type="checkbox"/>	9	Flange screw M8x45	3.00		982799
<input type="checkbox"/>	10	Transmission oil 1l, , (30759648), , (1161641)	1.00		31325136

<input type="checkbox"/>	11	Cable harness	1.00		30773381
<input checked="" type="checkbox"/>		* black, Differential Electronic Module (DEM)	1.00	NS	
<input type="checkbox"/>		4/82, , 8-POLE			
<input type="checkbox"/>		* Insulator, grey	1.00		30669161
<input type="checkbox"/>		54/74, , 4-POLE, For connection to the AOC coupling wiring harness.			
<input type="checkbox"/>		* Grommet	1.00		30656280
<input type="checkbox"/>		* Cable tie	2.00		983678
<input type="checkbox"/>	12	Flange screw	1.00		982803
		M8x65, , (965217)			
<input type="checkbox"/>	13	Cable tie	1.00		983750
<input type="checkbox"/>	14	DEM reload	1.00	SW	8688783
		Differential Electronic Module (DEM).			
<input type="checkbox"/>	15	Grommet	1.00		30656280
<input type="checkbox"/>	16	Clip	1.00		9470602
<input type="checkbox"/>	17	Oscillation damper, kit	1.00		30759074
		TJ-13007			
<input checked="" type="checkbox"/>		* Oscillation damper	1.00	NS	
<input type="checkbox"/>		* Companion flange, kit	1.00		30735852
		CH -445553			
<input type="checkbox"/>		* Companion flange, kit	1.00		31256140
		CH 445554-495000			
<input type="checkbox"/>		* Companion flange, kit	1.00		31259350
		CH 495001-			
<input checked="" type="checkbox"/>		* * Companion flange	1.00	NS	
<input checked="" type="checkbox"/>		* * Dust cover	1.00	NS	
<input type="checkbox"/>		* * Flange lock nut	1.00		31259267
		M16x1.5x10			
<input type="checkbox"/>	18	Filter	1.00		30787687
		-2008			
<input checked="" type="checkbox"/>		* Screw	2.00	NS	
		M5x18			
<input checked="" type="checkbox"/>		* Cap	1.00	NS	
<input checked="" type="checkbox"/>		* O-ring	1.00	NS	
		34.2x3 mm			

26/3/2013

PRINT