

V70 (00-08), 2007, B5244S2, M56, L.H.D, YV1SW654272634277, 634277



5/3/2019

PRINT

Camshaft control
(CVVT)

Fuel pressure regulation
(only vehicles with
demand controlled fuel
pumps)

Fuel trim

Ignition control

Knock control

Oil monitoring (2005-
certain markets only)

Regulating the cruise
control

Function

Camshaft control (CVVT)

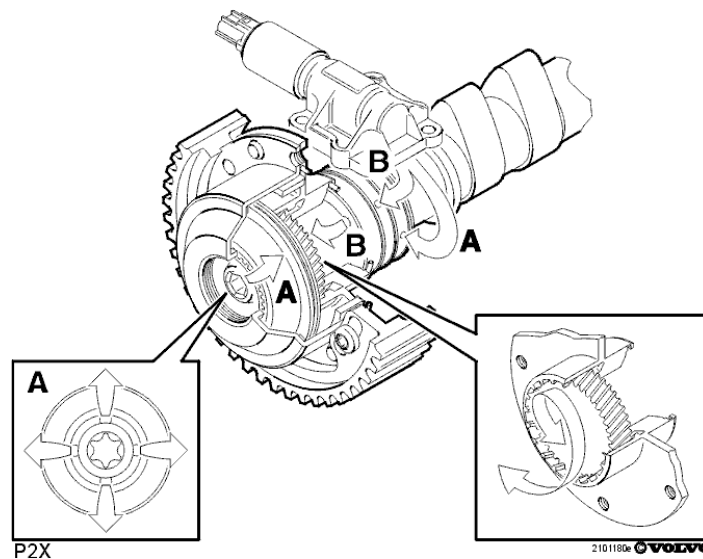

The engine control module (ECM) controls the camshaft reset valve (CVVT) steplessly. The pressure of the engine oil is used to regulate the CVVT unit. The CVVT unit is installed on the intake

camshaft on all B5244-engines.

There are 30 camshaft degrees (60 crankshaft degrees) between the limit positions.

The variable camshaft is hydraulically controlled by the engine oil. The camshaft turns when the camshaft reset valve (CVVT) releases lubricating oil into the front **(A)** or rear chamber **(B)** of the CVVT unit. The chambers are separated by a piston which is secured in the camshaft. The piston is secured in the cover of the CVVT unit by splines so that it moves easily. When the oil acts on the piston, the piston twists. The pulse wheel for the timing belt is on the outer cover of the CVVT unit.

Regulation is precise and rapid.

The camshaft reset valve (CVVT) has extremely fine ducts. This allows for precise regulation. However as a result the reset valve is sensitive to contaminants.

The main role of the variable camshaft is to reduce exhaust emissions, especially during cold starting. Idle quality is also improved.

Before the engine starts, there is an internal check consisting of the following stages:

1. When the ignition is switched on, there is an electrical check of the signal cable, the power supply cable and the solenoid. This check checks for a short-circuit to supply voltage or ground and open-circuits
2. The camshaft is checked to ensure that it is in the correct position in relation to the flywheel, with the camshaft in its 0 position (mechanical resting position). This can be done by comparing the signals from the camshaft position (CMP) sensor and the engine speed (RPM) sensor. If there is too much deviation between these, the camshaft reset valve (CVVT) is not activated and a diagnostic trouble code (DTC) is stored
3. During greater control of the variable camshaft, the amount of time taken to deploy the camshaft to the desired value is measured. This time is used partly to assess how long it takes to change the angle of the camshaft and partly to

disengage the variable camshaft if the time exceeds a certain maximum limit. The camshaft uses the engine oil and the oil pressure to turn itself. The rotation time varies, depending on factors such as engine speed (RPM), oil pressure and the viscosity of the oil (which depends on the temperature and quality of the oil)

4. The signal from the camshaft position (CMP) sensor is compared with the signal from the engine speed (RPM) sensor when the engine is turned over to ensure that it is correct. The check stops when the engine has started. If the check returns faulty values, a diagnostic trouble code (DTC) is stored and there is no camshaft control (CVVT).

Control

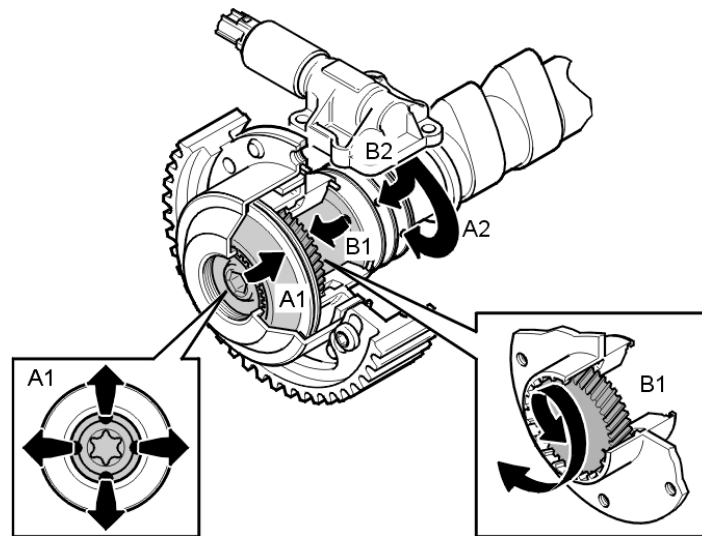

Control takes place as follows when deploying the camshaft:

1. Oil is forced from the engine lubricating system to the intake port on the reset valve
2. The engine control module (ECM) grounds the valve, the position of the piston in the valve changes and the oil is guided to the continuous variable valve timing (CVVT) unit chamber (A1) via the duct (A2) in the camshaft
3. The continuous variable valve timing (CVVT) unit hub is pressed backwards by the oil pressure. The continuous variable valve timing (CVVT) unit then rotates the hub and the carriers are joined by twisted splines

4. The oil flows to the engine oil pan via the outer ducts on the hub and the reset valve's return hose.

Control takes place as follows when returning the camshaft:

1. Oil is forced from the engine lubricating system to the intake port on the reset valve
2. The engine control module (ECM) breaks the ground connection for the valve. The piston in the valve is then pressed back by a spring. The oil flows to the continuous variable valve timing (CVVT) unit chamber (B1) via a duct (B2) in the camshaft
3. The hub of the continuous variable valve timing (CVVT) unit is forced forward by the oil pressure that is created. The continuous variable valve timing (CVVT) unit will rotate back to the non-deployed position
4. The oil flows to the engine oil pan via the center duct on the hub and the reset valve's return duct.

The above takes place

very quickly. The engine control module (ECM) controls the deployment and return of the reset valve continually at high frequency. This results in rapid and exact control. There are diagnostics for this function.

Knock control

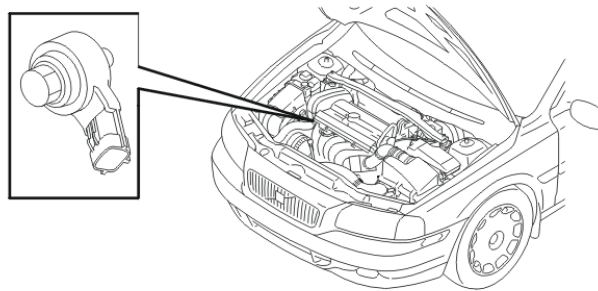

Knock occurs in the combustion chamber when the fuel and air mixture self ignites. This can occur either before or after the spark plug has produced an ignition spark. In both cases the gas in two or more places ignites in the combustion chamber.

This results in an extremely fast combustion process with flames from several directions. When these flames collide, the pressure in the cylinder increases rapidly and there is a mechanical knocking sound.

If any of the cylinders knock there is a specific

type of vibration in the cylinder block. These vibrations are transferred to the knock sensors (KS) which are screwed into place in the cylinder block. The resultant mechanical stress in the piezo electrical material in the knock sensors generates a voltage. The engine control module (ECM) can then determine which cylinder is knocking with the help of the camshaft position (CMP) sensor and the engine speed (RPM) sensor.

The knock sensors (KS) also interpret a proportion of normal engine sound. The control module is able to recognize the vibrations which correspond to knocking by filtering, amplifying and using software to evaluate the signal.

If the knock sensors (KS) detect knocking in the engine above a certain threshold value, the ignition timing is first retarded and then the fuel / air mixture is enriched to eliminate knocking.

Ignition control

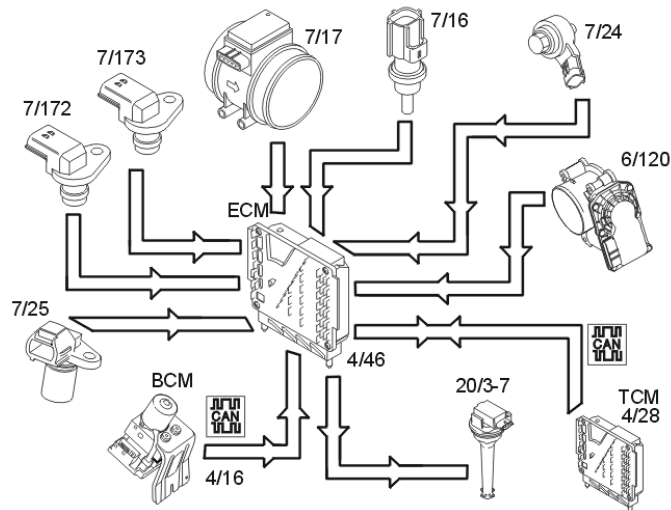

The following components are used for ignition control:

- engine speed (RPM) sensor (7/25)
- camshaft position (CMP) sensor (7/172-7/173)
- mass air flow (MAF) sensor (7/17)
- engine coolant temperature (ECT) sensor (7/16)
- throttle position (TP) sensor on the electronic throttle unit (6/120)
- knock sensor (KS) (7/24)
- transmission control module (TCM) (4/28)
- spark plugs with ignition coils (20/3-20/7)
- brake control module (BCM) (4/16).

The engine control module (ECM) calculates the optimum

ignition advance based on the software and information from the sensors. The engine control module (ECM) cuts the current to the ignition coil mounted on the cylinder to be ignited and produces a spark.

During the starting phase the engine control module (ECM) produces a fixed ignition setting. When the engine has started and the vehicle is being driven, the engine control module (ECM) calculates the optimum ignition setting, taking factors such as the following into account:

- engine speed (RPM)
- load
- temperature.

The engine control module (ECM) analyses the signal from the knock sensor (KS) when the engine reaches operating temperature. If any of the cylinders knock, the ignition is retarded for that specific cylinder until the knocking ceases. See also: Design:Knock sensor (KS)
The ignition then advanced to the normal position or until the knock recurs.

Before the transmission control module (TCM) changes gear, it

sometimes transmits a torque limiting request to the engine control module (ECM). The engine control module (ECM) then retards the ignition momentarily to reduce the torque, resulting in smoother gear changes and reducing the load on the transmission. There are different ignition retardation levels depending on the signals from the transmission control module (TCM). The return signal from the engine control module (ECM) to the transmission control module (TCM) confirms that the signal reached the engine control module (ECM). The Brake Control Module (BCM) transmits information to the engine control module (ECM) about deviations in the drive line. The signal is used to stop the diagnosis.

The engine misfires if the fuel does not ignite correctly.

Regulating the cruise control

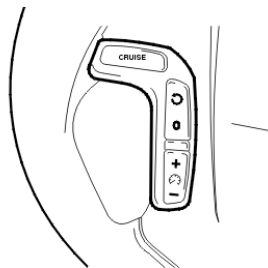

The cruise control function is an example

of distributed functionality.

The following components are used when regulating the cruise control:

- engine control module (ECM) (4/46)
- steering wheel module (SWM) (3/254)
- the cruise control control unit (3/4)
- central electronic module (CEM) (4/56) (clutch pedal position)
- brake control module (BCM) (4/16) (brake pedal position, speed signal)
- driver information module (DIM) (5/1) (cruise control lamp)
- transmission control module (TCM) (4/28)
- electronic throttle unit (6/120)
- stop lamp switch (3/9).

To activate cruise control the function must be switched on using the "CRUISE" button. A lamp lights up in the driver information module (DIM).

The driver activates the function by pressing the SET+ or SET- button. A message is then transmitted via the low speed side of the

Controller area network (CAN) to the central electronic module (CEM) which then transmits the message on via the high speed side of the Controller area network (CAN) to the engine control module (ECM). The engine control module (ECM) controls the throttle angle so that a constant speed is maintained using the vehicle speed signal from the Brake Control Module (BCM). The transmission control module (TCM) also receives a message indicating that cruise control is active via the Controller area network (CAN), so that the transmission follows certain shifting patterns when the cruise control is active.

If the accelerator pedal (AP) is depressed the speed increases as normal and then resumes to the stored value when the driver releases the accelerator pedal (AP) again.

The engine control module (ECM) continually stores the speed. If the cruise control is disengaged, if for example the driver depresses the brake pedal, the previous speed can be resumed by pressing the "RESUME" button.

Cruise control cannot be

activated at speeds
below a certain speed.

Cruise control is
disengaged:

- when the driver presses the clutch pedal or brake pedal
- when the driver presses the "CRUISE" button on the steering wheel
- when the driver depresses the "0" button on the steering wheel
- if "P" or "N" positions are transmitted on the controller area network (CAN) (applies to automatic transmissions)
- if the speed deviates too much from the set value
- when the control system detects a fault that prevents activation. (For further information, see diagnostic trouble code (DTC) information for the relevant diagnostic trouble codes (DTCs)).

**Oil monitoring (2005-
, certain markets
only)**

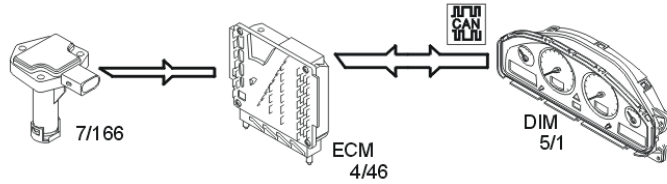

General

The following components are used for oil monitoring:

- oil level sensor (7/166)
- engine control module (ECM) (4/46)
- driver information module (DIM) (5/1).

One of the advantage of always monitoring the oil level is that the driver can then be informed, via the driver information module (DIM), if the oil needs topping up.

Oil quality detection

To calculate the quality of the oil, the capacitance of the oil is gauged and then compared with the capacitance of the air. (Capacitance is the ability to store an electrical charge). The capacitance of the oil and air is measured using both the capacitive gauge elements. The volume of contaminants in the oil increases the capacitance. This provides the electronics integrated in the oil

level sensor with an oil quality dependent input signal.

Oil temperature detection

The PTC resistor integrated in the oil level sensor is used to calculate the oil temperature. The resistance of the PTC resistor changes, depending on the oil temperature. The resistance increases as the oil temperature rises. This provides the electronics integrated in the oil level sensor with a temperature dependent input signal.

Oil level detection

The electronics integrated in the sensor calculate the oil level using the obtained values for oil temperature and quality. Temporary changes in the oil level in the oil trough must be taken into account to correctly calculate the oil level. This happens when cornering and taking hills for example. The engine control module (ECM) makes these calculations using the oil level sensor signal and a number of other parameters. These other parameters include the vehicle speed signal and the load signal.

Oil level sensor signal

The oil level sensor internally calculates the parameters for oil level, quality and temperature. A PWM signal is then generated and transmitted on a cable to the engine control module (ECM). The PWM signal consists of a pulse train. The first pulse in the pulse train represents the oil temperature. The second pulse represents the oil level. The third pulse represents the oil quality. A change in oil level, quality or oil temperature affects the pulse ratio of the relevant pulse.

Fuel trim

Overview

Fuel trim reduces exhaust emissions. Fuel trim reduces nitrous oxide (NO_x), carbon monoxide (CO) and hydrocarbon (HC) emissions. Theoretically, if the correct amount of oxygen is added during combustion, fuel can be converted to water (H_2O) and carbon dioxide (CO_2). Emissions would then be completely safe.

In practice considerable amounts of hydro-carbons (HC) and varying amounts of carbon monoxide (CO) and carbon dioxide (CO_2) remain.

Due to the high temperature and pressure, nitrous oxides such as NO and NO_2 are also formed. The common designation for these gases is nitrous oxides NO_x .

By speeding up the reaction between the remaining reactive components using a catalytic converter, these can be converted to water (H_2O), carbon dioxide (CO_2) and nitrogen (N_2).

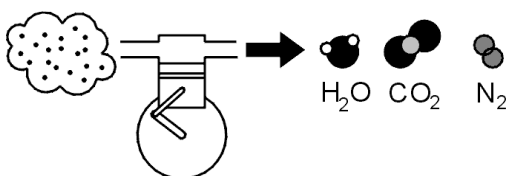
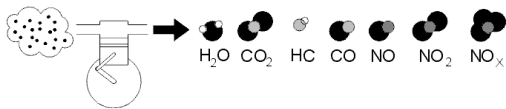
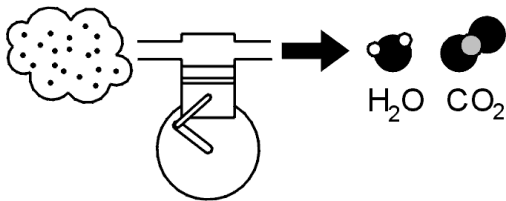

However this can only happen if the balance of hydro-carbons (HC), carbon monoxide (CO), oxygen (O₂) and nitrous oxides (NO_x) is exactly right in the exhaust. This happens when the fuel air mixture before combustion is 14.7 kg of air per kg of fuel. The Lambda value is then said to be one, ($\lambda=1$).

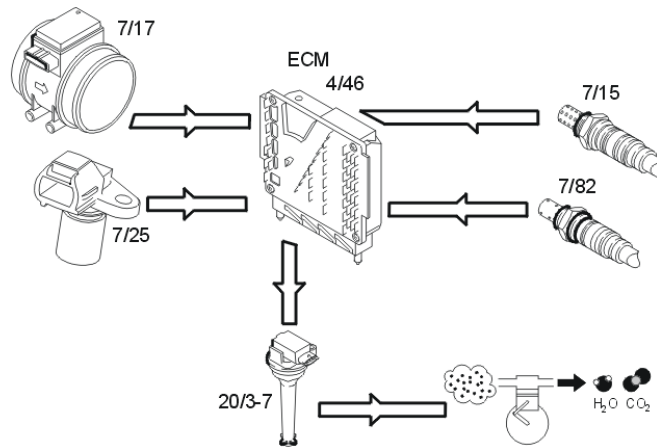

A base program in the engine control module (ECM) calculates the injection period based on data about load, i.e. the measured air mass and engine speed (rpm). The calculated injection time (from the base program) is then modified by a circuit (short-term fuel trim). The signal from the heated oxygen sensor (HO2S) is used to finely adjust the injection period so that $\lambda=1$ is reached. The short-term fuel trim is also a circuit that finely adjusts the injection period so that the fuel air mixture is optimized ($\lambda=1$). The control module also used the signals from the front and rear heated oxygen sensors

(HO2S) to correct the front heated oxygen sensor (HO2S) (offset adjustment) and thereby the injection period. This gives a higher degree of accuracy during fuel trim. Fuel trim is a rapid process which may take place several times a second. Adjustment of the calculated injection period calculated in the base program is limited.

The fuel trim can be read off using VIDA.

Adaptive functions

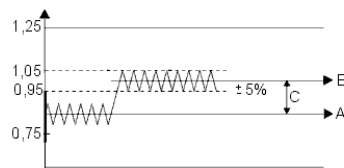
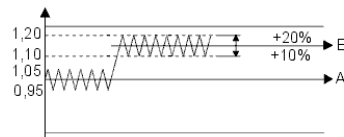
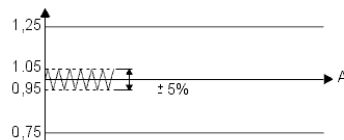

Certain factors, such as deviations in tolerance for certain components such as the mass air flow (MAF) sensor and injectors, intake air leakage, fuel pressure etc, will affect the composition of the fuel air mixture. To compensate for this, the engine control module (ECM) has adaptive (self learning) functions. When the engine is

new, the short-term fuel trim is assumed to vary cyclically around a nominal center line (A) 1.00 with, for example, a $\pm 5\%$ change in the injection period when fuel trim is active.

If there is air leakage for example, the short-term fuel trim will quickly be offset to a new position (B) and will then work for example between 1.10 (+10%) and 1.20 (+20%), although still at an amplitude of 5%, but with an offset in relation to the original center line (A). The injection period has then been increased to compensate the increase in the amount of air.

The adaptive functions will correct the change, so that the short-term fuel trim will work around the new center line (B) where it will again have its full range of control available.

Put simply, fuel trim is a measurement of the difference (C) between the original short-term fuel trim center line (A) and the new center line (B).

The adaptive functions are divided into several different operating ranges based on engine

speed and load.
The different adaptation ranges can be read off using VIDA.

The adaptive adjustments of the injection period are stored continuously in the engine control module (ECM). This means that under different operating conditions the fuel air mixture is obtained before the heated oxygen sensor (HO2S) is warm enough to function.

A diagnostic trouble code (DTC) will be stored in the engine control module (ECM) if any adaptation value is too high or too low.

Fuel pressure regulation (only vehicles with demand controlled fuel pumps)

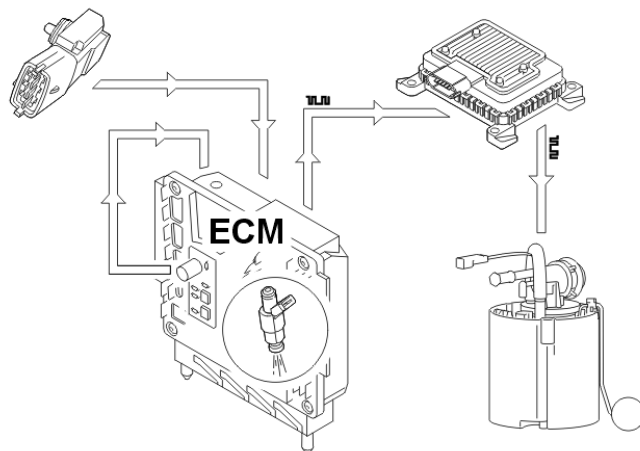

2303056n

General

Fuel pressure regulation for demand controlled fuel pumps (DECOS - DEMand COntrolled fuel Supply) means that the fuel pressure is controlled steplessly by varying the output of the fuel pump. The design of the system allows a greater maximum pressure (approximately 6.5 bar) in the fuel pump. This pressure is used in extreme situations, such as heavy engine load for example.

The following components are used for fuel pressure regulation:

- engine control module (ECM)
- the fuel pump control module
- fuel pressure sensor and fuel temperature sensor
- fuel pump (FP) with a by-pass valve
- atmospheric pressure sensor.

The time taken for the engine start procedure can be reduced by rapidly increasing the pressure in the fuel rail when the engine control module (ECM) receives a signal about the position of the ignition switch from the central electronic module (CEM).

The engine control module (ECM) is better able to calculate the

injection period using the signal from the atmospheric pressure sensor and fuel pressure sensor. This particular improves the cold starting characteristics of the engine.

The advantages of varying the output of the fuel pump so that it is not always at full power are:

- the total power consumption of the fuel pump (FP) is reduced, reducing the load on the power supply system
- the service life of the fuel pump (FP) is increased
- fuel pump noise is reduced.

Control

The engine control module (ECM) calculates the desired fuel pressure. A signal is then transmitted to the fuel pump control module indicating the desired fuel pressure. Serial communication between the engine control module (ECM) and the fuel pump control module is used to carry the signal. The fuel pump control module then operates the fuel pump unit to obtain the desired pressure using a pulse width modulation voltage on the ground lead. The fuel pump (FP) can be controlled

steplessly by changing the pulse width modulation (PWM) signal. Only that pressure which is required at that specific time will then be released to the fuel rail/injectors. The value of the pulse width modulation (PWM) signal is a measurement of the operational load of the fuel pump (FP) (% duty, 100% = maximum pressure). The engine control module (ECM) continuously monitors the fuel pressure using the signal from the fuel pressure sensor. This allows the desired fuel pressure to be reached, and if necessary a signal is transmitted to the fuel pump control module requesting that the fuel pressure is adjusted.

By-pass valve

When the injectors are closed because of too high pressure (during engine braking for example) there is a pressure peak. The by-pass valve in the fuel pump (FP) is used to even out the pressure peak. The opening pressure of the valve is approximately 6.5 bar. The by-pass valve also functions as a non-return valve, ensuring that the fuel pressure in the system is maintained when the engine is switched off. There is high pressure before the engine is started. This high

pressure means that the valve in the by-pass valve opens and the system is "flushed".

Passive safety

For safety reasons, the engine control module (ECM) shuts off the fuel pump (FP) if the supplemental restraint system module (SRS) detects a collision.

5/3/2019

PRINT